

Artech Panel PC' ler; Üretim ortamlarına entegre edilen, ağır endüstriyel ortam şartlarında yüksek performans sağlayan dokunmatik panel bilgisayarlardır.

Çizgi Teknoloji olarak Artech™ Endüstriyel Bilgisayar Çözümlerimiz ile otomotiv, beyaz eşya, tekstil, gıda ve ilaç gibi önde gelen birçok sanayi sektöründe üretim verimliliğini arttırmak, maliyet ve enerji kullanımını azaltmak için hizmet vermekteyiz.



Özellikler;

- ✓ Her Türlü Uygulama ve Ortam Şartı ile İlgili Çözüm Sunan Geniş Ürün Yelpazesi
- ✓ 3 Yıl Standart Garanti ve 5 Yıl Yedek Parça Temin Garantisi
- ✓ 10" / 15" / 17" / 21" TFT Ekran Model Seçenekleri
- ✓ 4:3 ve 16:9 Ekran Oranı Seçenekleri
- ✓ Geniş Görüş Açısı ve Farklı Dokunmatik Ekran Teknolojileri
- ✓ 0-70cdeg Çalışma Sıcaklığına Uygun Endüstriyel Sınıf SSD
- ✓ 0-80cdeg Çalışma Sıcaklığına Uygun Endüstriyel Sınıf RAM
- ✓ IP65 Ön Yüz Koruması
- ✓ Celeron / Pentium / iCore Seviyesinde İşlemci Seçenekleri
- ✓ WiFi Seçeneği (B/G/N/AC Destekli 5Ghz Teknolojisi)
- ✓ Vesa ve Panel Montaja Uygun
- ✓ Windows ve Android Çözümleri

Kullanım Alanları



ENDÜSTRİ



OTOMOTİV
SANAYİİ



BEYAZ EŞYA

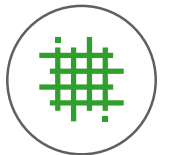

TEKSTİL



www.cizgi.net



www.artech-ipc.com.tr



cizgi-teknoloji



ÇİZGİ TEKNOLOJİ



Yüksek Performanslı
Fansız İşlemci



Kapasitif Multi- Flat
Touch Dokunmatik
Teknolojisi



4:3 Ekran Oranı



IP 65

IP65 Ön Panel Koruması



İnce Endüstriyel Toz
Korumalı Metal Gövde



Endüstriyel Panel Bilgisayar Basic Serisi IPC-715

SİPARİŞ KODU

Cpu	: Yüksek Performanslı Fansız Intel® Celeron j1900
Besleme	: 12 VDC(Adaptör Dahil)
Ram	: 4GB/8GB
HDD	: 64 GB/128GB/256 GB SSD
Wi-Fi	: 802.11 b / g / n (Opsiyonel)
Reader/Printer	: N.A.



SİSTEM

Cpu	: Yüksek Performanslı Fansız Intel® Celeron j1900
Cache	: By CPU
Memory	: DDR3 SoDIMM 4GB/8GB (0-80° Cdeg)
Video Ram	: Intel® HD Graphics
Chipset	: By CPU
Watchdog Timer	: 255 Level Reset

INPUT/OUTPUT

Serial Port	: 2x RS-232/422/485
Paralel Port	: 1 x Paralel Port
Usb Port	: 4 x USB 3.0
LAN	: Dual LAN; Dual Gigabit 10/100/1000
Wireless LAN	: 802.11 b / g / n (Opsiyonel)
Ses	: Line in & Out (AC'97 Codec Audio)

VERİ SAKLAMA

HDD Tipi	: Titreşime Karşı Dayanımlı Yuvada
HDD Depolama	: 64 GB/128GB/256 GB SSD (0-70° Cdeg)

BESLEME

Giriş	: 12 VDC
Adaptör	: Adaptör Dahil

LCD EKLAN

Boyut/Tip	: 15 LVDS 4:3
Maks. Çözünürlük	: 1024 x 768
Pixel Pitch	: 0.297mm x 0.297mm
Maks. Renk	: 16.7 M
Parlaklık	: 350cd
Kontrast Oranı	: 2000/1
Görüş Açısı	: 176°(H),176°(V)
Arka Işık MTBF	: 70,000 Hours
Dokunmatik Ekran	: 15" Touch - Projected Capacitive

VIDEO ÇIKIŞI

Tip	: HDMI/VGA
Maks.Çözünürlük	: 4096x2160

ÇEVRESEL

Çalışma Sıcaklığı	: 0 ~ 60°C
Depolama Rutubeti	: 5 ~ 95% (Non-Condensing)
Kasa	: Ağır Şartlara Dayanımlı Metal Gövde
Ön Çerçeve	: IP65 Önyüz Koruması
Ağırlık	: Ekran Ölçüsüne Göre Değişken
Boyut	: Ekran Ölçüsüne Göre Değişken
Montaj	: Panel,Duvar ve Vesa Montaj



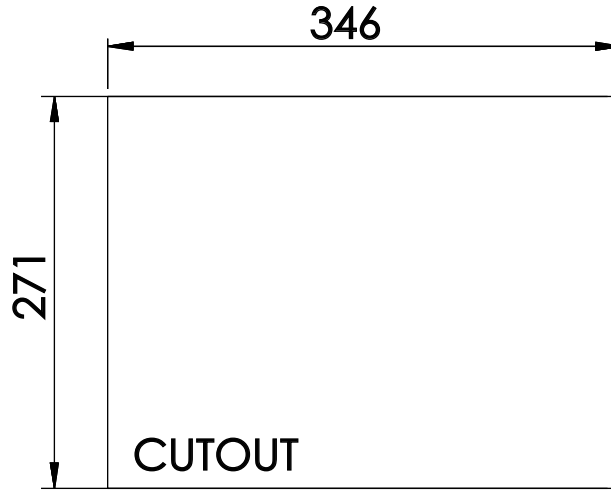
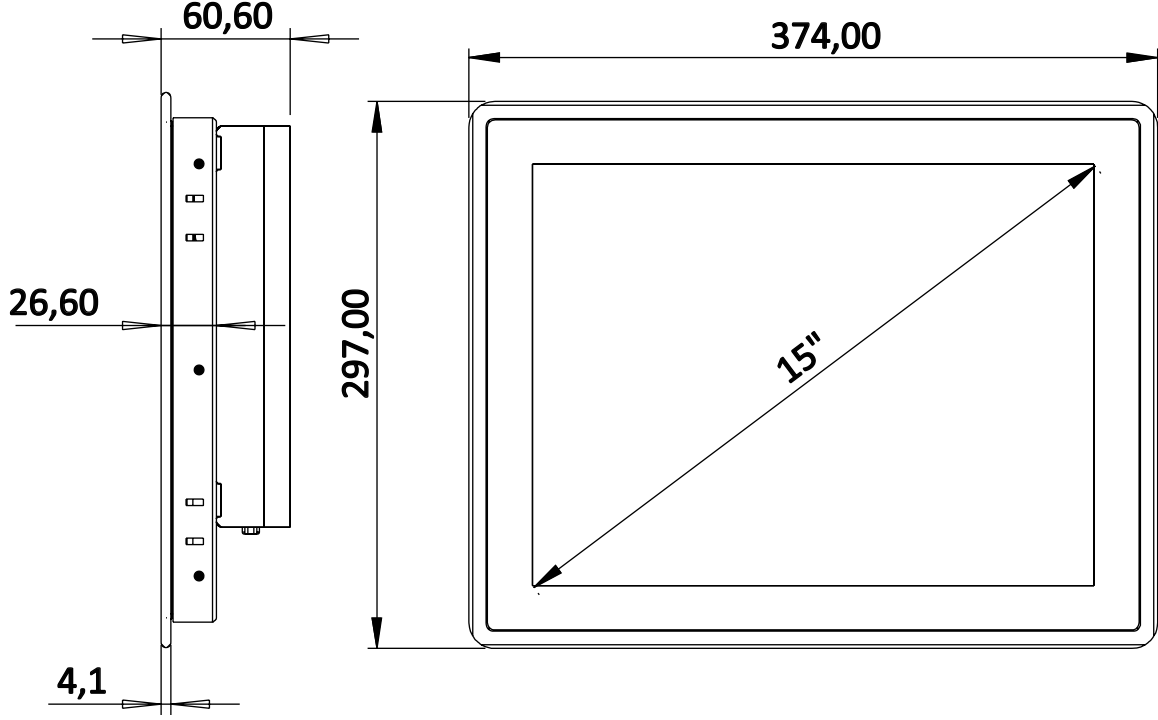

Tel: +90 216 365 82 50
Faks: +90 216 365 82 30



info@cizgi.net
www.cizgi.net



Merve Mah. Necip Fazıl Cad. No:8 34791
Sancaktepe - İstanbul

